

Omniprobe

14-hole omnidirectional probe



Additive manufacturing allows almost any geometry



Stainless steel, Inconel, Titanium



One-piece, robust design



Adjustable reference surfaces, connections, and software

Omniprobe	
Geometry	Straight, L-shaped
Number of holes	14
Max. length	Up to 200 mm (one part) (>200 mm for multipart designs)
Min. Tip diameter	>7.5mm
Tip geometry	Spherical
Material	Stainless steel, Inconel, Titanium
Fastening	Hexagonal, Square, one-sided flattened cylinder or custom
Connections	Standard 1 mm pressure tubes
Reference	Reference surface normal to Z axis
Temperature range	Up to 600°C
Angular range	$\pm 155^\circ$
Angular accuracy	$< \pm 1^\circ$
Velocity range	3 m/s to Mach 0.95
Velocity accuracy	$< \pm 1$ m/s

Table 1 General Data



Figure 1 Omniprobe

The 14-hole omnidirectional probe from Vectoflow allows the measurement of flow angles up to 155° . This probe is especially made for measurement tasks, where the angle of attack is unknown, or even reverse flow is expected.

Like all probes from Vectoflow, also the 14-hole probe is made by additive manufacturing, giving a high geometrical flexibility and a very high robustness at the same time.

Measurement error

The measurement error of a multi-hole probe depends on the pressure scanner used for the calibration and data acquisition.

We recommend the use of a scanner whose pressure range just covers the expected dynamic pressure, and which accuracy is 0.1 % full scale or better.

The lower the velocity, the higher becomes the impact of the pressure measurement error onto the determination of the flow velocity, as shown in figure 1 (for a scanner accuracy of ± 0.05 % FS).

An error of 1 m/s or 1% of the measured velocity — whichever is higher — is expected at higher speeds. For lower speeds, the error depends on the pressure scanner and increases the lower the speed.

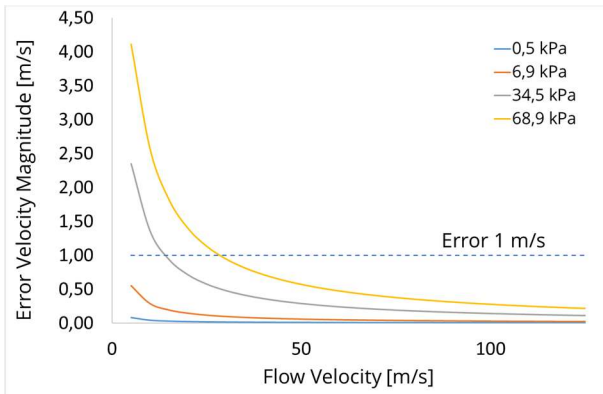

Figure 2 Dependence of velocity measurement error on pressure scanner range (0.05% FS accuracy)

Calibration process

The calibration of the process is always necessary for each manufactured multi-hole probe. Vectoflow has its own calibration wind tunnel, delivering flow speeds from 1 m/s up to Mach 1.

Vectoflow has a very rigid quality assurance, which ultimately leads to the highest possible measurement accuracy of the flow probes.

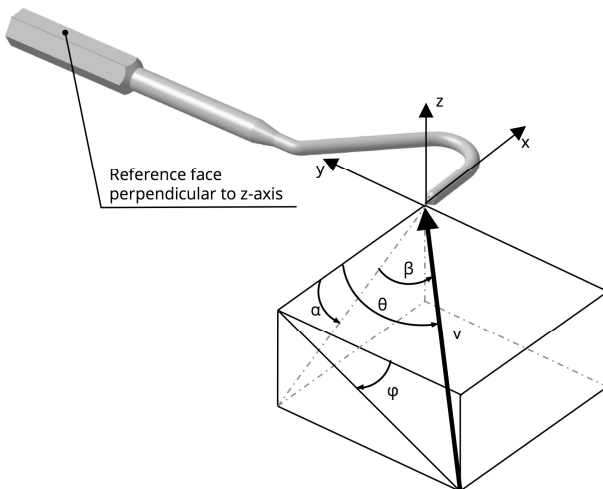

Figure 3 Flow angle definitions

During the calibration process, the probe is exposed to a steady flow with known conditions, while pitch and yaw angles change through thousands of positions. The definition of the flow angles is shown in Figure 3.

The following table shows the main characteristics of the Vectoflow calibration wind tunnel:

Calibration wind tunnel	
Angular range	$\pm 165^\circ$ (yaw axis), 180° (roll axis)
Max. Power	90 kW
Velocity range	From 1 m/s to Mach 1
Control parameters	Mach number, velocity (m/s)
Long-term velocity stability	$\pm 0.25\%$ (at M 0.1)

Table 2 Calibration wind tunnel characteristics

System solutions

Vectoflow provides not only flow probes, but complete measurement systems.

These solutions include:

- Probe
- Tubing connections
- Pressure scanner
- Software

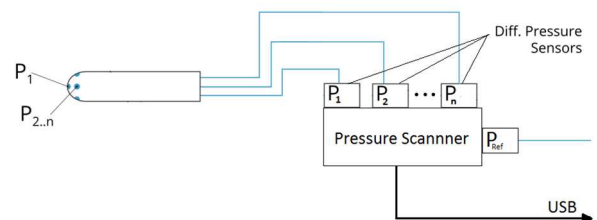

Figure 4 Multi-hole probe pressure tube connection

There is a variety of pressure scanners available, which integrate perfectly into the VectoVis Software.